

Type GTC

**Gate Valve  
Cast Steel, Bolted Bonnet  
Flanged / Butt weld ends**

**2" - 24" (50-600 mm)  
Class 150, 300, 600**

**Design in accordance with API 600**

## Applications

- Refineries, Power stations, Process & General Industry
- For water, steam, gas, oil and other non-aggressive media
- Further applications on request

## Operating data

- Pressure range up to 103.4 bar (1500 psi)
- Temperature range up to +593°C/1100°F
- Minimum temperature is 0°C (less than 0°C on request)
- Pressure-temperature ratings as per ASME B 16.34 Standard class

## Materials

- ASTM A 216 WCB from 0°C to 425°C
- ASTM A 217 WC6 from 0°C to 593°C
- ASTM A 351 CF8 from 0°C to 537°C

## Design

- As per API 600
- Pressure, Temperature rating as per ASME B 16.34
- Hard faced Seats (13% Cr / Stellite)
- Graphite gaskets and graphite packings with Braided wiping rings

## Variants on Request

- Bypass Arrangement
- Gear / Electrical Actuator
- Position indicator
- Locking Arrangement
- Lantern Ring
- Stem Protector
- Other Material of construction

## Remarks :

(Type Series Booklet References)

SICCA 800-2500 GTF / GLF / PCF	: 7240.1/12-11
SICCA 900-2500 GTC	: 7241.2/12-11
SICCA 900-2500 GLC	: 7242.2/12-11
SICCA 900-2500 SCC	: 7243.2/12-11
SICCA 150-600 GLC	: 7245.2/12-11
SICCA 150-600 SCC	: 7246.2/12-11
Operating instructions no.	: 0500.80/05-18 G3

## On all enquiries/orders please specify :

1. Type
2. ASME Pressure class
3. Size
4. Design pressure/temperature
5. Operating pressure
6. Operating temperature
7. Differential pressure
8. Material of construction
9. Flow Medium
10. Flow rate Min. / Max.
11. Type of end connection
12. Pipe Schedule, ID / OD
13. Variants
14. Type Series Booklet no.
15. Valve data sheet (if applicable)

When ordering spares, indicate valve serial number.

**Product features to our customer benefit**

6"-12" thrust bearing housing

Burnished stem 13% Cr. Steel (Hardened)

Two piece gland self aligning

2"-4" #150/ #600  
2"-3" #300

Graphite packing rings top & bottom rings of braided graphite

Seal ring seal welded to body (Swaged for 2"#150/300)

Flexible wedge body guided

Hardened Stainless steel back seat bush

For #150 (Flat gasket)

Encapsulated Gasket

Seal weld

Stem wedge connection meets API 600 pull test requirements

- Valves meet API 600 design requirements
- Body full bore to API 600 ensures streamlined flow hence no pressure drop.
- Body guided wedge ensures positive seating and eliminates side thrust
- Stem wedge connection meets API 600 pull test requirements.
- Harder seats (13% Cr / Stellite) minimises on line erosion (KSB recommends harder seats)
- Differential hardness between seat & wedge maintained to eliminate galling.

**Flow Seal**

- 13% Cr / Stellite body seats ( KSB recommends harder seats)
- Seat rings - seal welded to body
- Lapped seat and wedge faces for leak tightness
- Streamlined flow path hence no pressure drop

**Wedge Design**

- Flexible wedge ensures perfect seating
- Wedging action ensures leak tightness
- Leak tightness at low and high differential pressure

**'T' head stem wedge connection**

- Low, centre stem to wedge contact reduces the operating torque

Flexible Wedge

Seat

Gasket SS Spiral wound + Graphite

**Body seal**

**Bolted Bonnet**

- Encapsulated Gasket with Controlled Compression ensures leak proof joint and prevents unwinding of SS strips
- #150 valve with oval/rectangular bonnet has flat gasket

Burnished stem

Self-aligning gland

Gland bush

Die moulded graphite rings

Back seat bush

**Gland Seal**

- Die moulded graphite rings ensures effective stem sealing
- Top & bottom rings are braided graphite offer smooth wiping action & prevents Graphite depletion
- Burnished stem and smooth stuffing box surfaces improve gland sealing life
- Two piece self aligning gland arrangement
- Hardened back seat for maximum service life

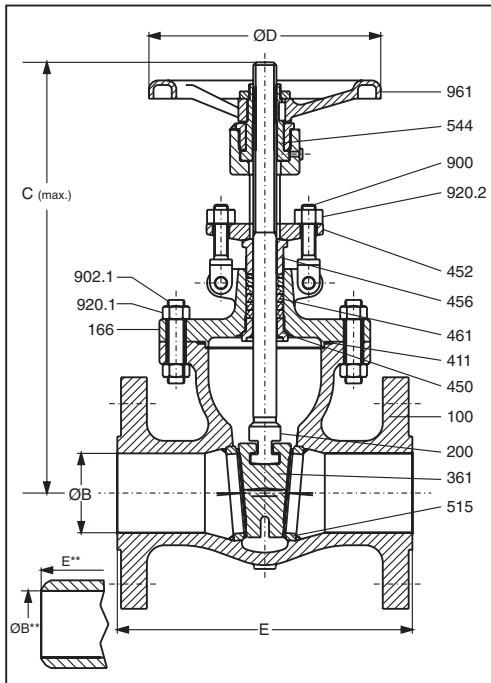

### Design Specifications

General valve design	: API 600
Pressure, temperature rating	: ASME B 16.34 Standard class
Flanged end design	: ASME B 16.5
Buttweld end design	: ASME B 16.25
End to end dimension / Face to face	: ASME B 16.10
Testing standard	: API 598

### Dimensions in mm

#### Class 150

	2"	3"	4"	6"	8"	10"	12"	14"	16"	18"	20"	24"
<b>E</b>	177.8	203.2	228.6	266.7	292.1	330.2	355.6	381.0	406.4	431.8	457.2	508.0
<b>ØB</b>	51.0	76.0	102.0	152.0	203.0	254.0	305.0	336.0	387.0	438.0	489.0	591.0
<b>C(max)</b>	370.0	445.0	530.0	720.0	940.0	1170	1400	1665	1910	2050	2275	2680
<b>ØD</b>	203.0	254.0	254.0	356.0	356.0	457.0	508.0	508.0	610.0	700.0	800.0	900.0
<b>E**</b>	215.9	282.5	304.8	403.4	419.1	457.2	501.7	572.0	609.6	660.4	711.2	812.8
<b>ØB**</b>	52.5	78.0	102.0	154.0	203.0	254.5	303.0	333.5	381.0	428.5	478.0	574.5

\*\* For Butt weld end valves schedule 40 for class 150.  
Alternate schedule on request.

#### Class 300

	2"	3"	4"	6"	8"	10"	12"	14"	16"
<b>E</b>	215.9	282.5	304.8	403.4	419.1	457.2	501.7	762.0	838.2
<b>ØB</b>	51.0	76.0	102.0	152.0	203.0	254.0	305.0	337.0	387.0
<b>C(max)</b>	410.0	505.0	625.0	840.0	1035	1245	1430	1740	1935
<b>ØD</b>	203.0	254.0	254.0	356.0	457.0	508.0	508.0	610.0	700.0
<b>E**</b>	215.9	282.5	304.8	403.4	419.1	457.2	501.7	762.0	838.0
<b>ØB**</b>	52.5	78.0	102.0	154.0	203.0	254.5	303.0	333.5	381.0

\*\* For Butt weld end valves schedule 40 for class 300.  
Alternate schedule on request.

#### Class 600

	2"	3"	4"	6"	8"	10"	12"
<b>E</b>	292.1	355.6	431.8	558.8	660.4	787.4	838.2
<b>ØB</b>	51.0	76.0	102.0	152.0	200.0	248.0	298.0
<b>C(max)</b>	435.0	535.0	645.0	895.0	1065	1255	1550
<b>ØD</b>	203.0	254.0	356.0	508.0	508.0	508.0	610.0
<b>E**</b>	292.1	355.6	431.8	558.8	660.4	787.4	838.2
<b>ØB**</b>	49.2	73.5	97.0	146.5	193.5	243.0	289.0

\*\* For Butt weld end valves schedule 80 for class 600. Alternate schedule on request.

### Materials

Part No.	Description	Material			
100	Body	A 216-WCB	A 217-WC6	A 351-CF8	A 351-CF8M
166	Bonnet	A 216-WCB	A 217-WC6	A 351-CF8	A 351-CF8M
200	Stem	A 479-410-2 / A 182-F6 A (>12")	A 479-410-2 / A 182-F6 A (>12")	A 276-304 / A 182-F 304 (>12")	A 276-316 / A 182-F316 (>12")
361	Wedge	A 217-CA15 A 216-WCB+13%Cr	A 217-WC6+ST6	A 351-CF8	A 351-CF8M
411 *	Gasket	SS 316 + GRPH	SS 316 + GRPH	SS 316 + GRPH	SS 316 + GRPH
450	Back Seat	A 276-410 (H)	A 276-410 (H)	A 276-304	A 276-316
452	Gland Flange	A 105/A 216-WCB	A 105	A 351-CF8	A 351-CF8M
456	Gland Bush	A 276-410	A 276-410	A 276-304	A 276-316
461	Gland Packing	Graphite	Graphite	Graphite	Graphite
515	Seat Ring	A 105+13%Cr	A 182-F11+ST6	A 351-CF8	A 351-CF8M
544	Stem Nut	A 439-D2	A 439-D2	A 439-D2	A 439-D2
900	Gland Bolt	A 307-B	A 307-B	A 182-F304	A 182-F304
902.1	Stud	A 193-B7	A 193-B16	A 193-B8	A 193-B8M
920.1	Hex. Nut	A 194-2H	A 194-4/7	A 194-8	A 194-8M
920.2	Hex. Nut		A 194-2H	A 194-8	A 194-8M
961	Handwheel	SG IRON / CS	SG IRON / CS	SG IRON / CS	SG IRON / CS

\* Flat graphite with SS reinforcement for # 150 only. SS Spiral wound gasket for # 300 and # 600.

**Testing**

Test / Test pressure	#150		#300		#600		Testing medium
	kg/cm <sup>2</sup>	psi	kg/cm <sup>2</sup>	psi	kg/cm <sup>2</sup>	psi	
Shell	32	450	79	1125	157	2250	Water
Seat / Back Seat	22	325	58	825	115	1650	
Seat	4 to 7	58 to 100	4 to 7	58 to 100	4 to 7	58 to 100	Air

**Rating for Group 1.1 Material : A 216 Gr. WCB <sup>(1)</sup>  
Standard Class**

Temperature		# 150		# 300		# 600	
°F	°C	PSI	Kg/cm <sup>2</sup>	PSI	Kg/cm <sup>2</sup>	PSI	Kg/cm <sup>2</sup>
-20 to 100	-29 to 38	285	20.4	740	52.0	1480	104.1
200	93.3	260	18.3	680	47.8	1360	95.6
300	148.9	230	16.2	655	46.1	1310	92.1
400	204.4	200	14.1	635	44.6	1265	88.9
500	260.0	170	12.0	605	42.5	1205	84.7
600	315.6	140	9.8	570	40.1	1135	79.8
650	343.3	125	8.8	550	38.7	1100	77.3
700	371.1	110	7.7	530	37.3	1060	74.5
750	398.9	95	6.7	505	35.5	1015	71.4
800	426.7	80	5.6	410	28.8	825	58.0
850	454.4	65	4.6	320	22.5	640	45.0
900	482.2	50	3.5	230	16.2	460	32.3
950	510.0	35	2.5	135	9.5	275	19.3
1000	537.8	20	1.4	85	6.0	170	12.0

1) Permissible, but not recommended for prolonged use above 800°F

**Rating for Group 1.9 Material : A 217 Gr. WC6 <sup>(1)(2)</sup>  
Standard Class**

Temperature		# 150		# 300		# 600	
°F	°C	PSI	Kg/cm <sup>2</sup>	PSI	Kg/cm <sup>2</sup>	PSI	Kg/cm <sup>2</sup>
-20 to 100	-29 to 38	290	20.4	750	52.7	1500	105.5
200	93.3	260	18.3	750	52.7	1500	105.5
300	148.9	230	16.2	720	50.6	1445	101.6
400	204.4	200	14.1	695	48.9	1385	97.4
500	260.0	170	12.0	665	46.8	1330	93.5
600	315.6	140	9.8	605	42.5	1210	85.1
650	343.3	125	8.8	590	41.5	1175	82.6
700	371.1	110	7.7	570	40.1	1135	79.8
750	398.9	95	6.7	530	37.3	1065	74.9
800	426.7	80	5.6	510	35.9	1015	71.4
850	454.4	65	4.6	485	34.1	975	68.5
900	482.2	50	3.5	450	31.6	900	63.3
950	510.0	35	2.5	320	22.5	640	45.0
1000	537.8	20	1.4	215	15.1	430	30.2
1050	565.6	20	1.4	145	10.2	290	20.4
1100	593.3	20	1.4	95	6.7	190	13.4
1150	621.1	20	1.4	65	4.6	130	9.1
1200	648.9	15	1.1	40	2.8	80	5.6

1) Use Normalised and tempered material only.

2) Not to be used over 1100°F

**Rating for Group 2.1 Material : A 351 Gr. CF8 <sup>(1)</sup>  
Standard Class**

Temperature		# 150		# 300		# 600	
°F	°C	PSI	Kg/cm <sup>2</sup>	PSI	Kg/cm <sup>2</sup>	PSI	Kg/cm <sup>2</sup>
-20 to 100	-29 to 38	275	19.3	720	50.6	1440	101.2
200	93.3	230	16.2	600	42.2	1200	84.4
300	148.9	205	14.4	540	38.0	1075	75.6
400	204.4	190	13.4	495	34.8	995	70.0
500	260.0	170	12.0	465	32.7	930	65.4
600	315.6	140	9.8	440	30.9	885	62.2
650	343.3	125	8.8	430	30.2	865	60.8
700	371.1	110	7.7	420	29.5	845	59.4
750	398.9	95	6.7	415	29.2	825	58.0
800	426.7	80	5.6	405	28.5	810	56.9
850	454.4	65	4.6	395	27.8	790	55.5
900	482.2	50	3.5	390	27.4	780	54.8
950	510.0	35	2.5	380	26.7	765	53.8
1000	537.8	20	1.4	355	25.0	710	49.9
1050	565.6	20	1.4	325	22.8	650	45.7
1100	593.3	20	1.4	255	17.9	515	36.2
1150	621.1	20	1.4	205	14.4	410	28.8
1200	648.9	20	1.4	165	11.6	330	23.2
1250	676.7	20	1.4	135	9.5	265	18.6
1300	704.4	20	1.4	115	8.1	225	15.8
1350	732.2	20	1.4	95	6.7	185	13.0
1400	760.0	20	1.4	75	5.3	150	10.5
1450	787.8	20	1.4	60	4.2	115	8.1
1500	815.6	15	1.1	40	2.8	85	6.0

1) At temperatures over 1000°F, use only when the carbon content is 0.04% or higher.

**Rating for Group 2.2 Material : A 351 Gr. CF8M <sup>(1)</sup>  
Standard Class**

Temperature		# 150		# 300		# 600	
°F	°C	PSI	Kg/cm <sup>2</sup>	PSI	Kg/cm <sup>2</sup>	PSI	Kg/cm <sup>2</sup>
-20 to 100	-29 to 38	275	19.3	720	50.6	1440	101.2
200	93.3	235	16.5	620	43.6	1240	87.2
300	148.9	215	15.1	560	39.4	1120	78.7
400	204.4	195	13.7	515	36.2	1025	72.1
500	260.0	170	12.0	480	33.7	955	67.1
600	315.6	140	9.8	450	31.6	900	63.3
650	343.3	125	8.8	440	30.9	885	62.2
700	371.1	110	7.7	435	30.6	870	61.2
750	398.9	95	6.7	425	29.9	855	60.1
800	426.7	80	5.6	420	29.5	845	59.4
850	454.4	65	4.6	420	29.5	835	58.7
900	482.2	50	3.5	415	29.2	830	58.4
950	510.0	35	2.5	385	27.1	775	54.5
1000	537.8	20	1.4	365	25.7	725	51.0
1050	565.6	20	1.4	360	25.3	720	50.6
1100	593.3	20	1.4	305	21.4	610	42.9
1150	621.1	20	1.4	235	16.5	475	33.4
1200	648.9	20	1.4	185	13.0	370	26.0
1250	676.7	20	1.4	145	10.2	295	20.7
1300	704.4	20	1.4	115	8.1	235	16.5
1350	732.2	20	1.4	95	6.7	190	13.4
1400	760.0	20	1.4	75	5.3	150	10.5
1450	787.8	20	1.4	60	4.2	115	8.1
1500	815.6	15	1.1	40	2.8	85	6.0

1) At temperatures over 1000°F, use only when the carbon content is 0.04% or higher.